

The Ideal Interior Shade To Filter Natural Light

With Mastershade® Interior Screens



MERMET 

The **MASTERSHADE**® 6000 & 7000 interior screen system from **Sunair**® is the perfect solution for maintaining shade and comfort in your home or office. The Mastershade® dramatically decreases heat and glare caused by the sun. Our screens are the ideal solution for solar protection, shading or total blackout by controlling or blocking the sunlight that penetrates your windows and doors. Our shades also protect your furniture, curtains, and floor coverings! Imagine sitting at your computer or watching TV without being disturbed by too much sunlight and still having a view of the outside. The screens are available in many fabric types, frame colors and are operated by either a remote-controlled battery motor, hardwired motor, or manual chain operated.



www.SunairAwnings.com

Enjoy the sun when you want it and shade when you need it with the Mastershade® ISC Interior screen system. Our screens will significantly reduce indoor temperature while lowering cooling costs. Depending on the type of fabric used and size of the window, you may realize a reduction in air-conditioning costs. Sunair® has two ISC Screen models to fit your needs, depending on the size of the window.

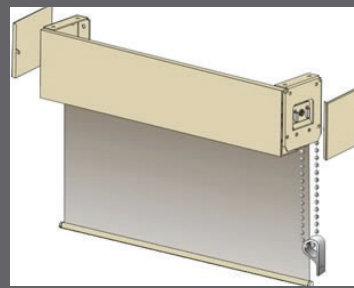

ISC6000 with Pull Chain



3" Square Fascia

Color Matching Bead Chain



4" Square Fascia

Available Fascia & Frame Colors

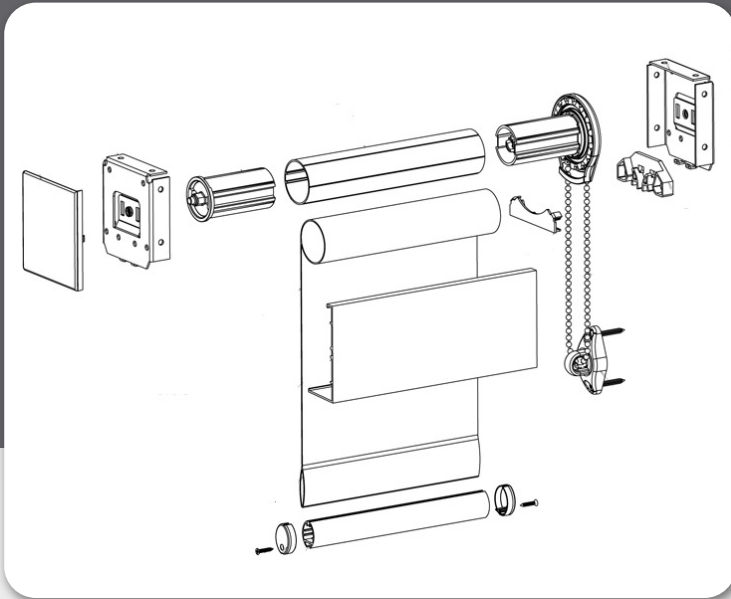
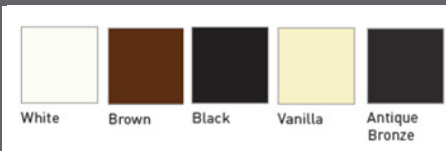

ISC6000

Max width 10 ft.
Max drop 14 ft.

ISC7000

Max width 14 ft. / 24 ft.
Max drop 14 ft.

Note: Max drop depends on size for all models above and type of fabric used. For ISC7000 wider widths are possible with splits.



SUNAIR® only offers the best mesh for your screen. There are different mesh fabrics available offering both exceptional transparency and sun blocking capabilities. Our mesh patterns vary from 1 –10% open to completely opaque for room darkening purposes. Ask your SUNAIR® dealer which mesh fabric is best for your application.



SUNPROOFING AMERICA!™

MOTOR OPTIONS

SOMFY MOTORS feature an integrated radio receiver that allows you to operate the shade by remote. Hardwire or chargeable battery operated Sonesses motors are available. The optional "Sunis and Thermo Sunis sun sensors lower the shades automatically with the sun's intensity. Add optional smart controls for controlling the shade with your tablet or smartphone.



Sunis & ThermoSunis Indoor WireFree™ RTS Sensors



AUTHORIZED DEALER:

www.SunairAwnings.com

Sunair® reserves the right to change engineering without notice ©2023 Sunair® Awnings & Screens.

Sunair® Awnings, 7785 Rt. 175 Jessup, MD 20794
©2023 Awnings Unlimited Inc.
Jessup, MD 410.799.1145 Phoenix, AZ